

**ORDINANCE 7-11
(replaces 7-10)**

SIDEWALK ORDINANCE

AN ORDINANCE REQUIRING AND DIRECTING THE GRADING, PAVING, CURBING, AND REPAIRING OF SIDEWALKS AND CURBS IN THE BOROUGH OF MERCERSBURG, FRANKLIN COUNTY PENNSYLVANIA BY THE OWNER OR OWNERS OF THE PROPERTY RESPECTIVELY FRONTING THEREON, AND PRESCRIBING THE CHARACTER AND WIDTH OF SUCH SIDE WALKS AND THE MATERIALS OF WHICH THE SAME SHALL BE CONSTRUCTED.

Be it enacted and ordained by the Mayor and Town Council of the Borough of Mercersburg, Franklin County, Pennsylvania and it is hereby enacted and ordained by authority of the same.

**SECTION I
DEFINITIONS**

As used in this ordinance, the following words have the following meanings:

"Adjacent/Abutting Property" Any lot or parcel of land adjoining, bordering or touching the street (not an alley) as defined herein.

"Borough". The Borough of Mercersburg

"Curb" is the edge where a raised pavement/sidewalk/footpath, road median, or road shoulder, the purpose of which is two-fold: first as a gutter for proper drainage of the roadway, and second for safety, to keep motorists from driving onto the shoulder, median, sidewalk, or pavement. The curb is to be constructed per the standards section VI of this ordinance.

"Defect" or "defective condition" means a public sidewalk or curbing that has a defect or defective condition because it exhibits one or more of the following characteristics:

- (a) Vertical separations equal to three-fourth inch (3/4") or more;
- (b) Horizontal separations equal to three-fourth inch (3/4") or more;
- (c) Holes or depressions equal to three-fourth inch (3/4") or more;
- (d) Spalling over fifty percent (50%) of a single square or panel of sidewalk with one or more depressions equal to one-half inch (1/2") or more;
- (e) A single square or panel of sidewalk and/or curb cracked in such a manner that no part thereof has a piece greater than one (1) square foot, or is cracked in such a manner that it constitutes danger or potential danger to the public;
- (f) A sidewalk or curb with any part thereof missing to the full depth;

(g) A deviation on the staked and constructed grade equal to three-fourth inch (3/4") or more;

(h) Covered in whole or in part with weeds or other plants, garbage, junk, rubbish, debris, solid waste, bird or animal droppings or any nuisances, obstructions or hazards which makes or tends to make pedestrian travel either dangerous or impractical;

(i) If the concrete has settled, allowing water to pond to depth of one (1) inch or more.

"Driveway" A private drive providing access between a public or private street or access drive and the parking area for a property.

"Existing Sidewalk" means sidewalks which are presently in place even though they may not conform to the specifications hereinafter provided for.

"Maintain" or **"maintenance"** means the duty to remove and replace a public sidewalk and/or curb, or a portion of a public sidewalk and/or curb, with all work to be performed in accordance with established Borough specifications in effect at the time the work is commenced, so as to render the sidewalk and/or curb free from defect(s). Maintaining a sidewalk and/or curb shall mean that the sidewalk and/or curb shall be free of defect(s) and/or defective conditions.

"PENNDOT or PDT" shall mean Pennsylvania Department of Transportation

"Permittee" shall mean any natural individual or individuals, firm or firms, company or companies, corporation or corporations who has applied for and/or received a permit for the construction, reconstruction, repair or replacement of sidewalks and/or curbs.

"Property owner" or **"owner"** means any natural individual or individuals, firm or firms, company or companies, corporation or corporations who is the record holder of legal title or other legally recognizable equitable interest.

"Public Street" A dedicated thoroughfare in the Borough that is designated for public travel and transportation, affording the principal means of access to the abutting property. This does not include any alleys, privately owned roads, or other privately owned paved surfaces or other means of access.

"Repair/Replacement" means the adjustment, removal, realignment, patching or installation of any sidewalk or curb in accordance with the inspection policy and repair/replacement standards of this ordinance.

"Sidewalk" means the surfaced portion of that area between the curb lines of the roadway and the adjacent property lines intended for the use of pedestrians. The sidewalk shall be constructed as per the standards in Section VI of this ordinance.

SECTION II

RESPONSIBILITY OF THE ADJACENT OR ABUTTING PROPERTY OWNER ON EXISTING SIDEWALKS AND CURBS.

The adjacent or abutting property owner is responsible for keeping sidewalks and curbs free of any defect(s) or defective conditions by maintaining any sidewalks and/or curbs on or abutting their property in accordance with this Ordinance. In the event that the adjacent or abutting property owner does not properly maintain the sidewalk and/or curb, or the sidewalk and/or curb is subject to a defect and/or defective condition as defined in this Ordinance, the Borough Manager is authorized to require the replacement and/or repair to cause compliance with this Ordinance.

- A. All sidewalk and/or curb inspections as indicated in this Ordinance and as set forth by the inspection policy of Section III, shall be performed by the Borough Manager or his/her Designee. The Borough Manager or his/her designee will determine what sidewalks or curbs are in need of replacement and/or repair based on whether the sidewalk and/or curb has any defect(s) or defective conditions as defined in this Ordinance.

- B. Clearances of sidewalk pathways

It is the responsibility of the abutting property owner to maintain sidewalks free and clear of all obstacles. This is to include a pathway width of no less than three feet wide on the walkway surface and eight feet in height from obstacles such as, but not limited to, tree branches, shrubbery, or any other item that may limit the pedestrian traffic upon the sidewalk.

- C. No person shall remove, deface, damage, destroy or otherwise alter the condition of any sidewalk and/or curb within the Borough of Mercersburg in a manner which would result in any defect(s) or defective conditions without the express written authorization of the Borough of Mercersburg. Any damage or destruction that results in any defect(s) or defective condition, which is occasioned by any party, whether it be accidental or otherwise, shall be repaired or replaced immediately by the abutting property owner at their expense. Actions of third persons shall not alleviate the abutting owner of the responsibility to maintain, replace or repair damaged, destroyed or defective sidewalks.

- D. It is the sole responsibility of the property owner to obtain permits for the construction, alteration, or repair of curbs on PennDot roadways within the Borough limits which require a PennDot permit.

SECTION III

INSPECTIONS, NOTIFICATION, INVOICING AND PAYMENT.

- A. The Borough Manager or his/her designee shall be responsible for inquiries and investigation of complaints regarding the condition of sidewalks and/or curbs.

- B. It is the intention of this Ordinance to implement the replacement, repairs and new installation of sidewalks and/or curbs over a period of time by utilizing available resources. The public funding of sidewalk and/or curb replacement, repairs or installation shall be determined by the sole discretion of Borough Council.
- C. It shall be the responsibility of the Borough Manager or his/her designee to supervise all sidewalk and/or curb construction and maintenance, including inspection, and to enforce the provisions of this Ordinance.
- D. The Borough Manager or his/her designee will conspicuously mark any inspected sidewalk and/or curb in need of repair. The Borough Manager or his/her designee shall also notify a property owner when sidewalk and curb installation is required under Section V of this Ordinance. The Borough Manager will send notification via certified mail to the adjacent property owner that sidewalks and/or curbs are in need of repair/replacement or that sidewalk and curb installation is required, giving ninety (90) days to repair/replace or install the sidewalk and/or curb. In no case shall the time period specified exceed ninety (90) days, except during inclement or unseasonable weather in which case the party responsible for the repair/replacement or installation shall post a financial guarantee in lieu of the repair. Said guarantee must be in the form of cash, a certified check or an irrevocable letter of credit and said guarantee shall be calculated in accordance with the Borough's schedule of fees. In the event the owner of the premises cannot be located, then notice shall be posted on the property. In the event that an adjacent or abutting property owner disputes the notification by the Borough Manager, an appeal may be directed to the Mercersburg Borough Council. All appeals shall be filed with the Borough Office within thirty (30) days of the date of the written notification that sidewalk or curb repairs/replacements or installation are required. If no appeal is filed within thirty (30) days of the date of the written notification, the ability of the property owner to appeal shall be considered waived. The thirty (30) day appeal period shall not toll the ninety (90) day period within which the sidewalk or curb must be repaired/replaced or installed. In the event that the sidewalk or curb is not repaired/replaced or installed within the ninety (90) day period, the Borough Manager or his/her designee will cause the sidewalk or curb to be repaired/replaced or installed by the Borough or its designee. The Borough Manager will cause all costs of the repair/replacement or installation of the sidewalk and/or curb that is completed by the Borough or its designee to be assessed to the adjacent or abutting property in accordance with this Ordinance.
- E. The cost of repair/replacement of the sidewalks and/or curbs, in accordance with the Borough's schedule of fees, will be invoiced to the adjacent/abutting property owner. The owner will have thirty (30) days from the date of the invoice to make payment in full. If any portion of the invoice remains unpaid thirty (30) days after the date of invoice the Borough Manager may request that the Borough Solicitor file a municipal lien against the property. The lien shall be subject in all respects to the law provided for the filing and recovery of municipal liens. The cost of repair/replacement incurred by the Borough shall also be recoverable in accordance with 53 P.S. §46801-46806. The Borough may also

pursue any other remedy at law to collect any amount that is delinquent under this section.

- F. Any sidewalk and/or curb that is damaged as a result of utility work done solely for the Borough, Mercersburg Water Authority, or Mercersburg Sewer Authority shall not be assessed to the adjacent property owner.

**SECTION IV
SIDEWALKS, CURBS OR DRIVEWAYS LOCATED ON PRIVATE STREETS OR
WITHIN THE RIGHT-OF-WAY OF A PRIVATELY OWNED ROAD OR STREET**

This ordinance is not applicable to any sidewalks or curbs located on private streets or within the right-of-way of a privately owned road or street.

**SECTION V
INSTALLATION OF NEW SIDEWALKS OR CURBS**

- A. The Borough reserves the right to require the installation of sidewalks and/or curbs at any time on the recommendation of the Borough Manager, his or her designee or the Borough Engineer.

**SECTION VI
SIDEWALK AND CURB SPECIFICATIONS**

All sidewalks or portions thereof hereafter constructed or repaired shall comply with the following specifications:

- A. All sidewalks shall be constructed to grade established by existing adjoining walks or, in the absence of the foregoing, by the grade established by the Borough Manager, his/her designee, or the Borough Engineer, and shall be paved with a 4-inch thick single course of cement concrete using limestone aggregate, which shall have a compressive strength of not less than 3,500 pounds per square inch within 28 days of placement, with a minimum of four inches of aggregate base consisting of AASHTO # 57 limestone. Individual pavers (concrete, stone, or clay brick) may be substituted for concrete when authorized by the Borough, and must be set on a minimum of four inches of aggregate base AASHTO #57 limestone with a 1" sand top setting layer.
- B. All sidewalks shall be at least four feet in width. Wider walks to a maximum of eight feet may be required by the Borough in commercial or industrial areas or multiple family areas, due to anticipated traffic and the development of the area.
- C. Paving joints shall be perpendicular to sidelines at intervals consistent with adjoining or abutting sidewalks and not greater than the sidewalk width. One-inch expansion joints shall be placed through the walk at least every 16 feet, and between walks and other rigid structures.

- D. The surface shall be roughened with a brush or other equipment to prevent smooth and slippery surfaces.
- E. All sidewalks extending from the line of the abutting lot to the curb line shall be constructed so that the outer edge of said walk shall rest flush with the top of the curb, and no part of said walk shall be taken for private use by lowering or cutting down the same next to the building; and said walk shall be built up to the building on a uniform grade.
- F. All sidewalks shall be constructed so as to incline upwards from the street side edge of the sidewalk toward the boundary of the lot at a rate of not less than one-fourth inch nor more than one-half inch in one foot, except as otherwise authorized by the Borough.
- G. A minimum of 16 square feet of concrete sidewalk ("one square", or 4'x4' area, between transverse score marks) shall be replaced in all cases, regardless of existing damage
- H. Schedule 40 PVC Pipe or Metal inserts shall be placed in the fresh concrete to accommodate any existing or proposed street signage.
- I. Care should be taken when finishing fresh concrete around utility any valve/meter/cleanout lids or access parts to assure workability of lids or access parts after the concrete cures.
- J. Curbs shall be constructed as shown on the Borough of Mercersburg Standard Construction Drawing for Cement Concrete Curb and as follows:
- K. Where roof gutter downspout or yard drains are directed under the new sidewalk to the curb face, trench gutter drains with grates must be used under the sidewalk. Fiberglass, concrete, plastic or metal trench drains are permissible. Piping of any type or size under the sidewalk is prohibited.
1. **Excavation.** Excavate as required. Remove existing curb, pavement, and sidewalk to neat lines when indicated. Saw cut and remove existing pavement 1 foot beyond face of curb. Then compact the material, upon which the curb is to be constructed, to a firm even surface.
 2. **Forms.** Use of acceptable metal forms is required, however, use of flexible wooden forms on sharp curves and short tangent sections is acceptable. Forms that will not discolor the concrete shall be used.
 3. **Placing, Finishing, and Curing Concrete.** Conform to weather restrictions for concrete placement if placed in cold weather. Place the concrete in the forms in layers not exceeding 5 inches in depth when spading, or layers not exceeding 15 inches in depth when using a vibrator to eliminate voids. Provide drainage openings through the curb, at the elevation and of the size required, where indicated or directed. Smoothly and evenly finish the top surface of the curb using a wood

float. While the concrete is still plastic, round the edges of the face and back of the curb. Place depressed curbs for drives or curb ramps, where indicated or directed. Place bars as indicated for depressed curb at drives as required. Cure concrete as specified by PennDOT Publication 408.

4. **Curb Machine.** The concrete curb may be placed with an acceptable, self-propelled machine. Uniformly feed the concrete to the machine so that it maintains the shape of the section without slumping after extrusion. The Representative will not allow voids or honeycomb on the surface of the finished curb. Immediately after extrusion, perform any additional surface finishing.
5. **Joints.** Form or saw contraction joints to dimensions shown on Standard Drawing. Place 3/4-inch pre-molded expansion joint material conforming to the cross sectional area of the curb where indicated and at the end of the workday. Do not place expansion joint material at Type C precast inlet tops. Prepare and caulk joints according to caulking manufacturer's recommendations.
6. **Removal of Forms.** Do not remove forms until such time that it will not be detrimental to the concrete. Correct irregular surfaces by rubbing with a carborundum stone. Do not brush finish or plaster. Fill minor defects with mortar.
7. **Backfilling and Embankment.** As soon as possible after the removal of forms, backfill the voids in front and back of the curb, using acceptable embankment material. Complete embankments in back of raised curbs, as indicated, except carefully compact the embankment by means of mechanical tampers, or rollers, if permitted, not exceeding 8 tons. Replace existing pavement and sidewalk damaged or removed during construction in accordance with Borough specifications. Dispose of unsuitable and surplus material in a lawful manner.
8. **Curb Modification.** Modify curb construction within existing pavement limits and existing structures, where indicated or directed. Drill holes and insert dowel bars with nonshrink mortar, as required.

SECTION VII GENERAL SIDEWALK REGULATIONS

A. Driving Over Sidewalk or Curbs.

No person or persons shall push, draw, or back any vehicle or tractor, except a bicycle, over any side walk, or use, ride, or drive any vehicle or tractor, except a bicycle, thereon, unless it be in crossing the same to go to a store, house, yard, or lot where no other suitable crossing or means of access is provided, and then not until he shall have made a sufficient position to protect the sidewalk. Said vehicle or tractor shall not remain on the sidewalk as to block or obstruct its use.

B. Penalty for Injuring Sidewalk and/or Curb.

Any person who shall break or otherwise injure any sidewalk and/or curb in any manner which causes defect(s) or a defective condition shall within ten (10) days thereafter cause the same to be repaired or reconstructed in accordance with the specifications in this Ordinance. Failure to do shall be a violation of this Ordinance.

C. Driving Over Sidewalk Without Protection.

No property owner or occupant shall permit or suffer any vehicle or tractor to be driven or otherwise to pass, go over, or upon the sidewalk and/or curb opposite to such house or store for the purpose of loading or unloading such vehicle, or for any purpose whatsoever, unless the operator of such vehicle shall have first provided for the protection of the sidewalk and/or curb with plywood, mats, etc.

D. Permit required for the construction, reconstruction, repair or replacement of sidewalks and/or curbs.

It shall be unlawful for any person, firm or corporation to remove, construct, reconstruct, repair or replace a sidewalk and/or curb without first obtaining a permit from the Borough Secretary, to be in a form prescribed by said secretary. The charge for said permit shall be as set forth in the Borough's schedule of fees.

E. Financial Security required for new construction of curbs and/or sidewalks.

Security in the form of a performance bond, irrevocable letter of credit, certified check, cash, or other security acceptable to the Borough, shall be deposited with the Borough Secretary, to be held without interest, prior to a permit being issued by the Borough Secretary for new construction of curbs and/or sidewalks (hereinafter referred to in this subsection as IMPROVEMENTS). The amount of security shall be determined as set forth in the Borough's schedule of fees. The security shall be used to reimburse the Borough for all costs and expenses incurred by it (as evidenced by itemized bills thereof), in completion of the IMPROVEMENTS in the event that the permittee becomes insolvent before completing the IMPROVEMENTS or the permittee does not complete the IMPROVEMENTS within twelve (12) months of the date that the permit was issued. Upon completion of the IMPROVEMENTS, the permittee shall notify the Borough in writing that the IMPROVEMENTS been completed and are ready for final inspection. Upon receipt of the notice that the IMPROVEMENTS have been completed the Borough shall have forty-five (45) days, from receipt of such request, within which to allow the Borough Manager, his/her designee, or the Borough's Engineer to certify, in writing, to the Borough that the IMPROVEMENTS have been completed in accordance with this Ordinance. Upon such certification, the Borough Secretary shall release or authorize release by the lending institution of the security.

**SECTION VIII
VIOLATIONS.**

Any person, firm, corporation, or other entity who violates any of the provisions of this Ordinance shall be guilty of a summary offense, and upon conviction shall be sentenced to pay a fine of not less than fifty dollars (\$50.00) and not more than one thousand dollars (\$1,000.00)

and cost of prosecution. Each day a violation of this Ordinance continues to exist shall constitute a separate violation.

**SECTION IX.
SEVERABILITY.**

If any section, paragraph, clause, phrase or part of this Ordinance is for any reason held invalid by any court of competent jurisdiction, or any agency, department or commission empowered for such purpose, such decision shall not affect the validity of the remaining provisions of this Ordinance, and the application of those provisions to any person or circumstances shall not be affected thereby.

**SECTION X.
INCONSISTENT ORDINANCE REPEALED**

All other Ordinances or parts of Ordinances, insofar as the same are inconsistent with the provisions of this Ordinance, shall be, and the same are hereby repealed.**SECTION XI.
DATE OF EFFECT**

This Ordinance shall take effect five (5) days from its approval.

ORDAINED AND ENACTED into an Ordinance this 25th day of Aug. 2014

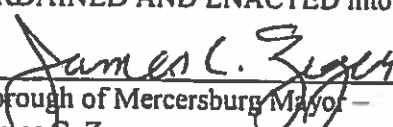

Borough of Mercersburg Mayor -
James C. Zeger

Borough Council President -
Thomas Suddeth

ATTEST:

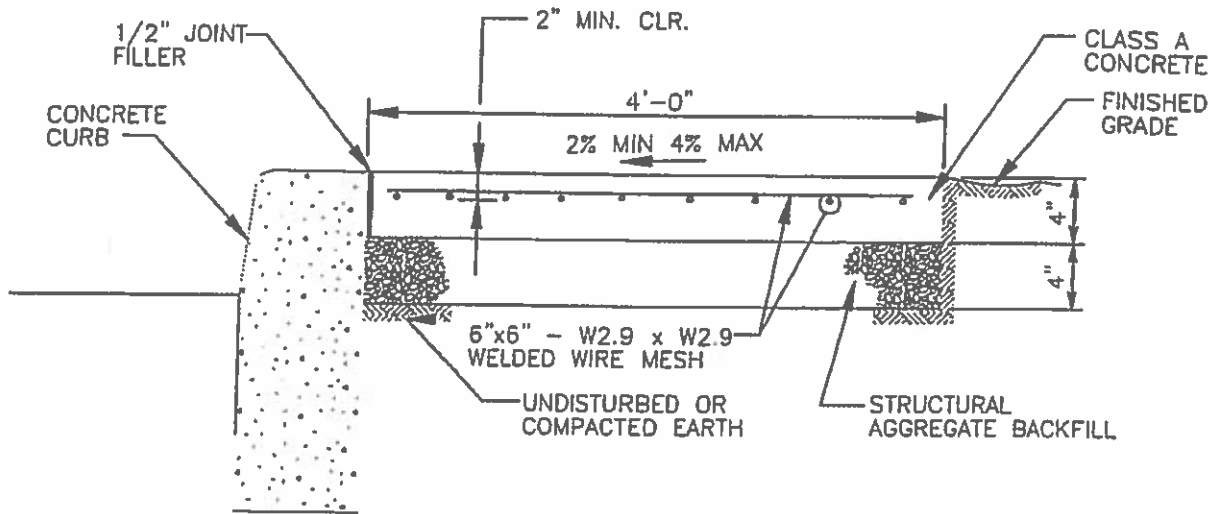

Borough of Mercersburg Secretary -
Dawn L. Scheller

Approved this 25th day of Aug. 2014

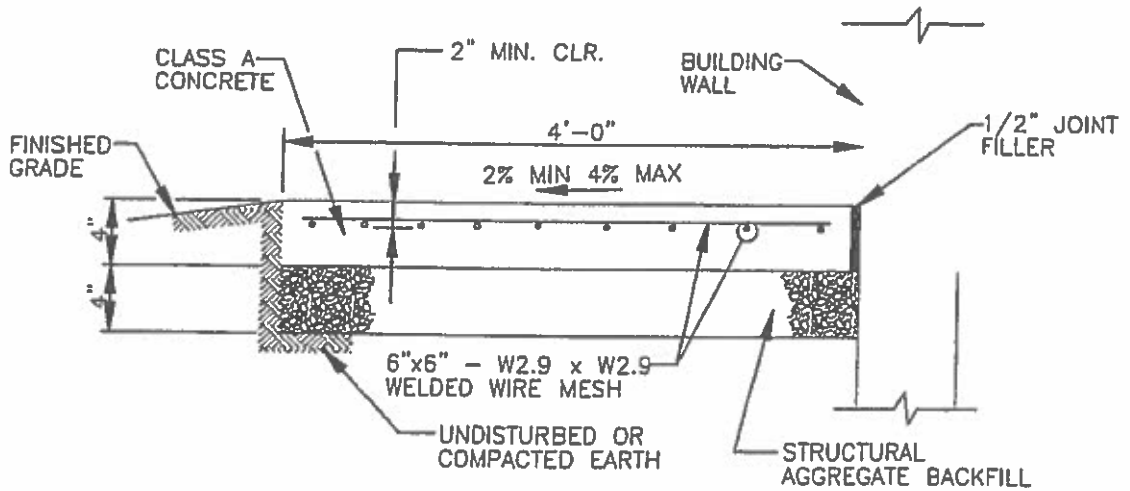

SIDEWALK SECTION AT CURB

NO SCALE



SIDEWALK SECTION AT BUILDING

NO SCALE

BOROUGH OF MERCERSBURG
STANDARD CONSTRUCTION DETAILS

SIDEWALK AND CURB DETAIL



Gannett Fleming

Engineers + Planners + Surveyors

Scale: 1/4" = 1'-0"	Drawn by: J.L.	Checked by: J.L.	Date: 11/11/11
Project: 11111111	Sheet: 3.1	Revision: 1	Author: J.L.
Client: 11111111	Project: 11111111	Sheet: 3.1	Date: 11/11/11



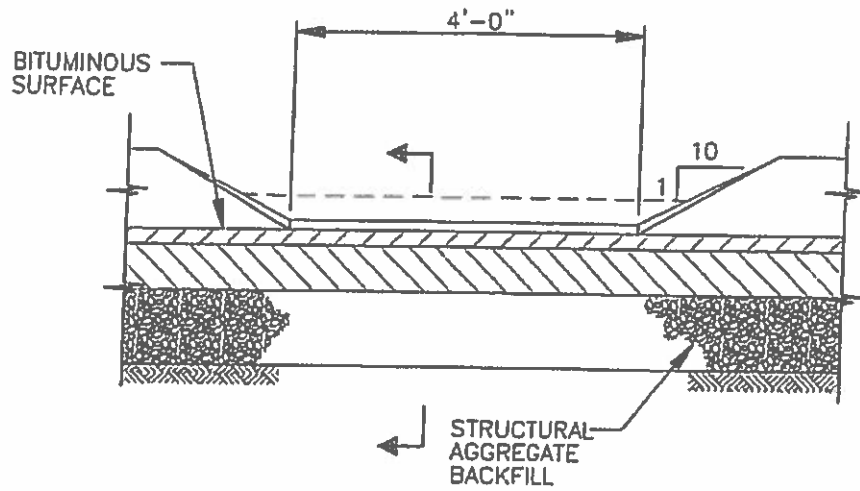

ELEVATION

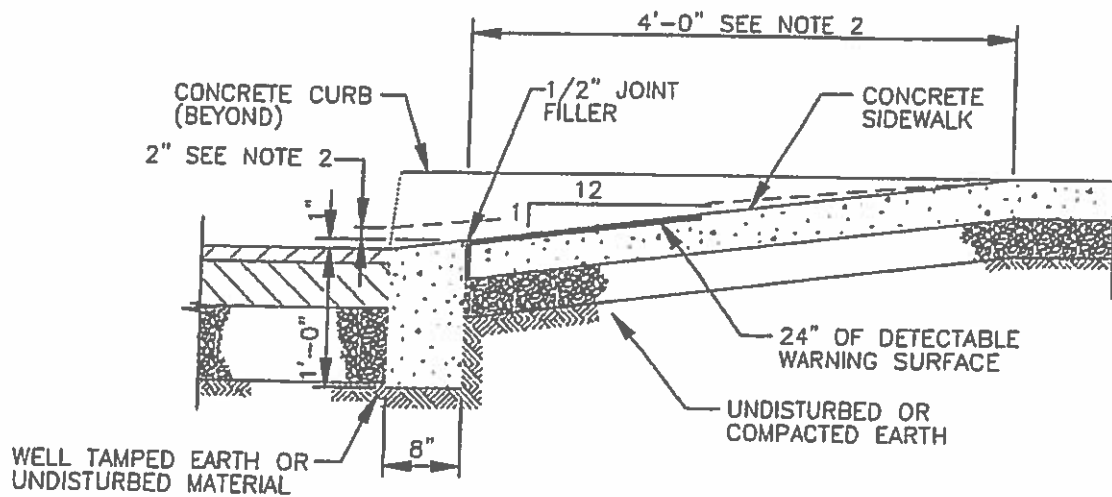

SECTION

NOTES:

1. CURB CUT RAMP TO BE CONSTRUCTED IN ACCORDANCE WITH PADOT AND ADA REQUIREMENTS.

CURB CUT RAMP DETAIL

NO SCALE

BOROUGH OF MERCERSBURG
STANDARD CONSTRUCTION DETAILS
SIDEWALK AND CURB DETAIL



Gannett Fleming
Engineers + Planners + Surveyors
1500 Pennsylvania Drive, Suite 200
York, PA 17402-3410
Tel: 717.766.1410

Scale	AS SHOWN
Proj. No.	15-006-010
Drawn	J.L.
Checked	J.L.
Date	12/28/15
Sheet	1 of 1



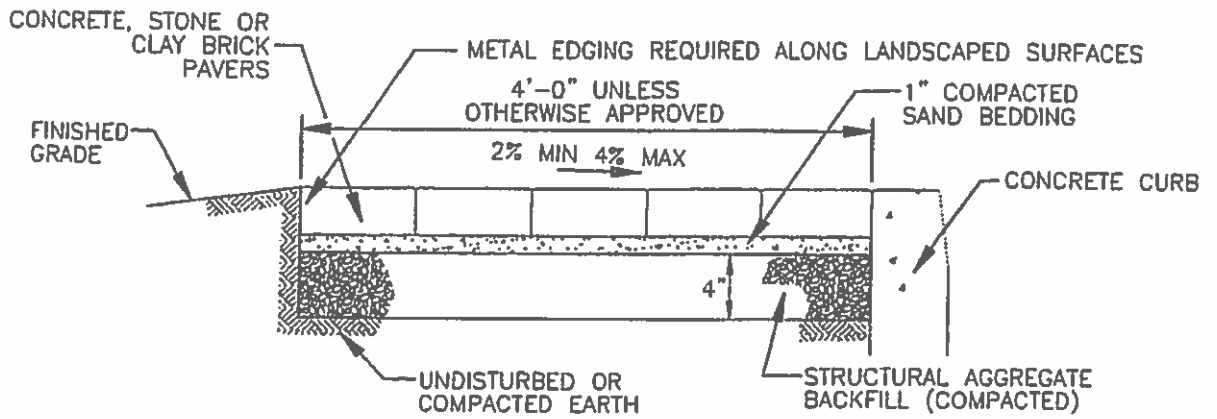

TYPICAL SIDEWALK PAVER SECTION

NO SCALE

NOTE

PAVER PATTERN SHALL MATCH EXISTING AND/OR ADJACENT PATTERNS



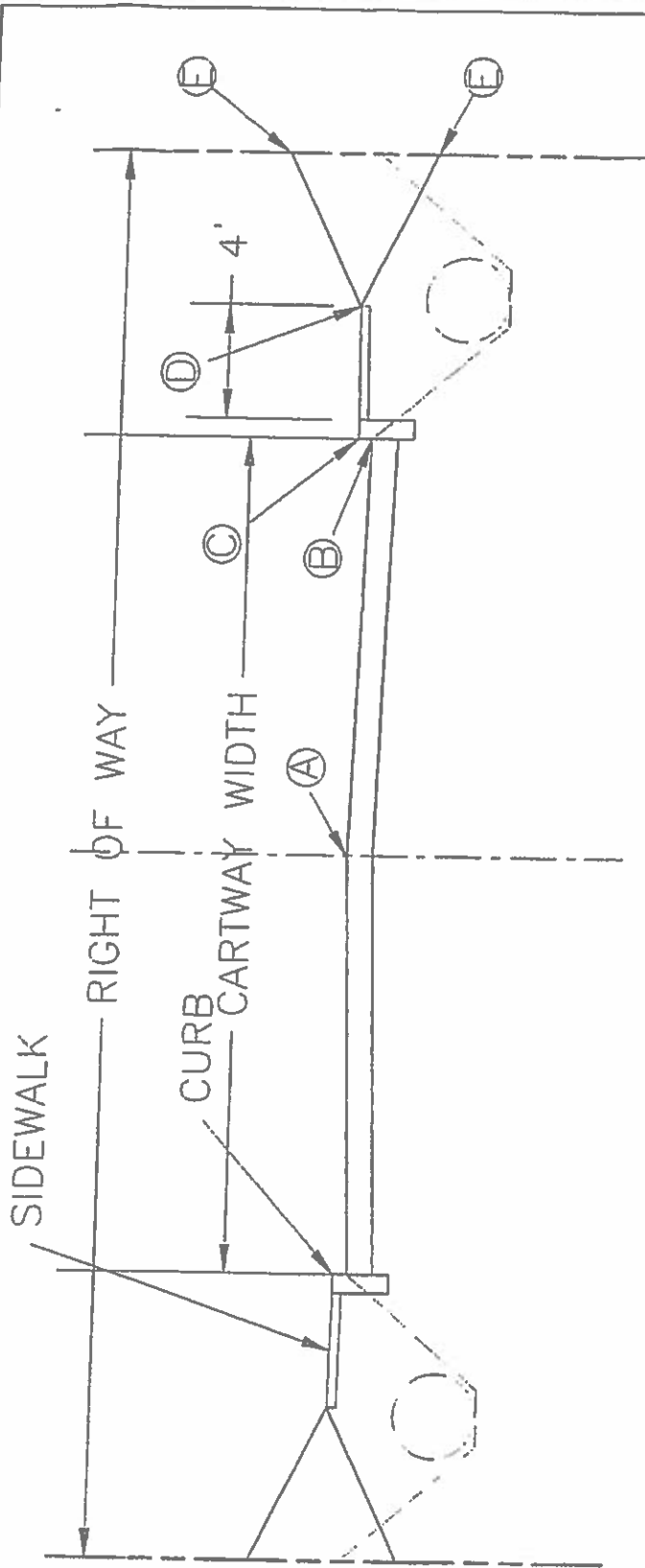

SIDEWALK CONSTRUCTION EXEMPTION CRITERIA

1. IF C IS \geq 2' ABOVE B -AND- IF E IS \geq 2' ABOVE OR BELOW C
2. IF E IS \geq 2' ABOVE OR BELOW C
3. IF ROADWAY DRAINAGE WILL BE ALTERED BY THE INSTALLATION OF SIDEWALK AND/OR CURB

BOROUGH OF MERCERSBURG
STANDARD CONSTRUCTION DETAILS
SIDEWALK AND CURB CONSTRUCTION
EXEMPTION CRITERIA



Gunnett Fleming
Engineers + Planners + Surveyors
 210 Pennsylvania Plaza, Suite 200
 York, Pennsylvania, PA 17403
 Tel: 717/766-1800
 Fax: 717/766-1824

Date to Print	
Printed on	06/22/20
Printed by	2-7/2020
Project	
Sheet No.	23
Total Sheets	23
Date	06/22/20
Scale	AS SHOWN

